

Cummins Diesel

NT-280-IF

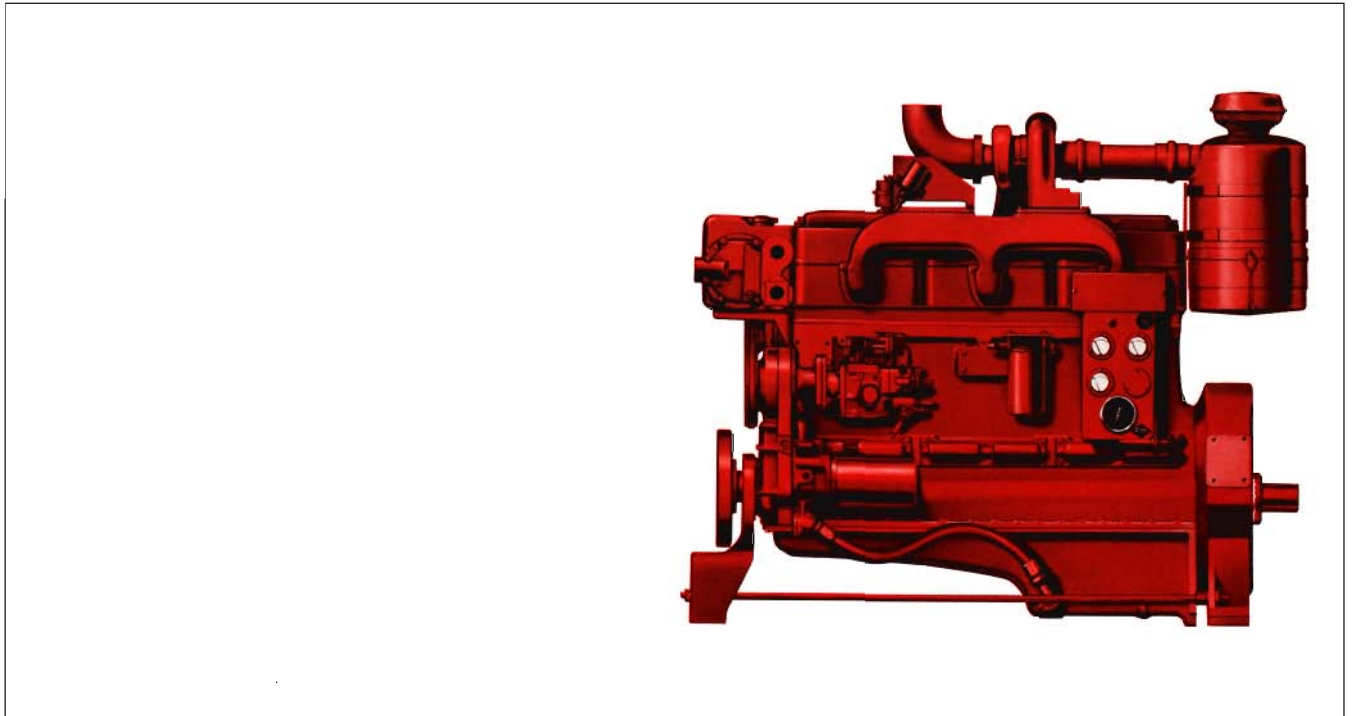

Specifications

Number of Cylinders	6
Bore and Stroke—in.	5½ x 6
Piston Displacement—cu. in.	855
Operating Cycles	4
Crankcase Oil Capacity—gals.	8.5
Engine Coolant Capacity—gals.	9
Net Weight with Standard Accessories (lbs.) .	3150

Specific ratings are shown on rear page.

Design Features

Bearings: Precision type, steel backed inserts. 7 main bearings, 4½" diameter. Connecting Rod — 3⅞" diameter.

Camshaft: Single camshaft controls all valve and injector movement. Induction hardened alloy steel with gear drive.

Camshaft Followers: Roller type for long cam and follower life.

Connecting Rods: Drop forged, 12" center to center length. Rifle drilled for pressure lubrication of piston pin. Taper piston pin end reduces unit pressures.

Cooler, Lubricating Oil: Tubular type, jacket water cooled.

Crankshaft: High tensile strength steel forging. Bearing journals are induction hardened. Fully counterweighted.

Cylinder Block: Alloy cast iron with removable, wet liners.

Cylinder Heads: Each head serves two cylinders. Drilled fuel supply and return lines. Corrosion resistant inserts on intake and exhaust valve seats.

Fuel System: Cummins PTR Fuel system with integral, fly-ball type, mechanical variable speed governor. Camshaft actuated injectors.

Gear Train: Heavy duty, located at front of cylinder block.

Lubrication: Force feed to all bearings, gear type pump. All lubrication lines are drilled passages, except pan to pump suction line.

Pistons: Aluminum, cam ground, with four compression and one oil ring.

Piston Pins: 2" diameter, full floating.

Turbocharger: Cummins, T-50, top mounted.

Valves: Dual intake and exhaust each cylinder. Each valve 1⅞" diameter. Heat and corrosion resistant face on exhaust valve.



Listed under Underwriters' Laboratories, Inc., reexamination service for fire protection applications.

Listed by Associated Factory Mutual Fire Insurance Companies for fire protection applications.

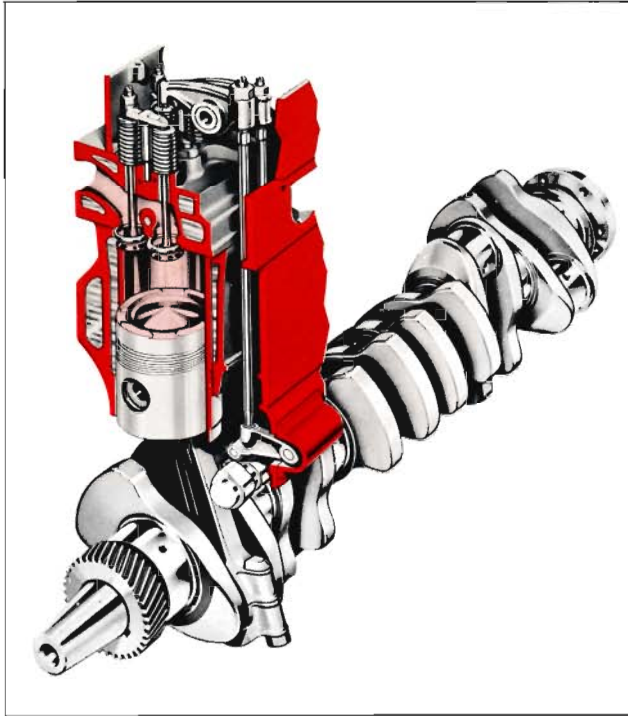

Big Displacement Design Features

- 1 **Internal Fuel Lines:** Drilled passages in cylinder heads eliminate threaded fuel line connectors and external lines.
- 2 **Large Intake and Exhaust Passages:** Minimize restriction of air and exhaust flow. Allows maximum air charge for clean burning, top economy.
- 3 **Overhead Valves:** Precision machined from high strength alloy steel. Intake valves are of silichrome steel. Exhaust valves of big displacement models are nitrogen steel for high temperature strength and faced with corrosion resistant material.
- 4 **Open Type Combustion Chamber:** Gives most efficient combustion . . . most power from each gallon of fuel.
- 5 **Replaceable Wet-type Cylinder Liners:** Dissipate heat faster. Liners are easily replaced without reboring block.
- 6 **Conventional Push Rod and Rocker Lever Arrangement:** Activates valves and injectors from a single camshaft. Roller type camshaft followers are used for long life.
- 7 **Cam-ground Pistons:** Assure perfect fit at operating temperatures.
- 8 **Alloy Cast Iron Cylinder Block:** Follows proven design and material specification to achieve maximum durability.
- 9 **Large Volume Water Passages:** Give even flow of coolant around cylinder liners, valves, and injectors to draw excess heat from combustion chamber. Centrifugal pump circulates large volumes of water.
- 10 **Connecting Rods:** Forged from high tensile strength alloy steel. I-beam section gives maximum strength. Large diameter piston pins are full-floating. Tapered piston pin end used for superior load distribution and maximum crown material on piston.
- 11 **Counterweighted Crankshafts:** Precision machined from high tensile strength steel forgings. Bearing journals are induction hardened for long life.

Engines for fire pump service should only be applied at the listed ratings of any one of the following: Underwriters' Laboratories, Inc., Factory Mutual Fire Insurance Companies. These ratings are as follows:

Underwriters' Laboratories Ratings:

255 HP @ 1750 RPM
 255 HP @ 1900 RPM
 255 HP @ 2100 RPM

Factory Mutual Ratings:

255 HP @ 1750 RPM
 255 HP @ 1900 RPM
 255 HP @ 2100 RPM

Performance

The horsepower ratings listed above represent performance at sea level altitude (29.92 inches of mercury) and 60°F. intake air temperature. Ratings represent performance of the engine with all standardly fitted parasitic losses deducted, including fuel system, lubricating oil pump, water pump, air cleaner and battery charging generator.

Curves represent performance on No. 2 diesel or furnace oil. The net horsepower ratings are to be derated 5% for each 1000 feet above sea level, in accordance with National Board of Fire Underwriters Standard No. 20.

Cummins Engine Company, Inc., Columbus, Indiana 47201
Cummins Americas, Inc., Columbus, Indiana, U.S.A.
Cummins Diesel Australia, Ringwood, Australia
Cummins Diesel International Limited
Cummins Engine Company Ltd., London, England

